

Precision Turbine Flowmeters

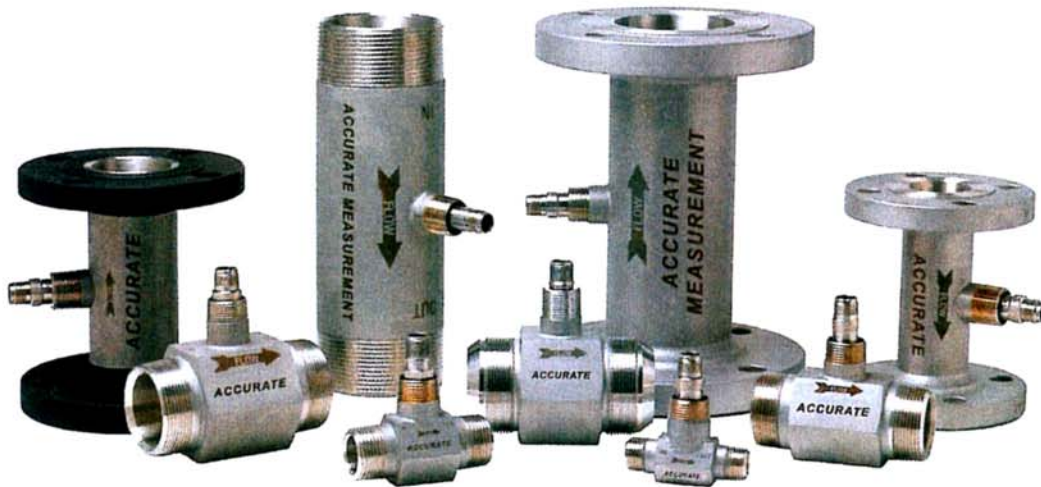

- Flowrates: .25 to 12000 GPM
35 to 12000 ACFM
- Temperature Range: -430 to +1000° F
-256.7° C to 537.8° C
- Linear Output
- High Resolution
- Standard and Custom End-fittings

Design Applications

- Liquid and Gas Measurement
- Batching
- Blending
- Filling
- Process Control



P.O. Box 268 - 1138 Wall Road
1-800-456-1453
www.AccurateMeasurement.net

Installation Dimensions

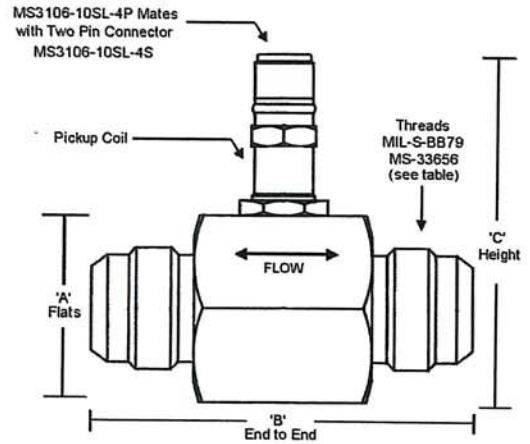

MS FLARED TUBE Sizes 1/4" – 2" (0.635 - 5.08 cm)

SIZE INCHES(CM)	DIMENSIONS INCHES (CM)			END CONNECTIONS	APPROX. WT. INCHES (CM)
	A	B	C		
1/4" – 1/2" (0.635 - 1.27 cm)	1 1/8" (2.8575 cm)	2 9/16" (6.51 cm)	3" (7.62 cm)	3/4 -16UNJF-3A	.38 / .173
5/8" (1.59 cm)	1 1/8" (2.8575 cm)	2 3/4" (6.985 cm)	3" (7.62 cm)	7/8 -14UNJF-3A	.75 / .341
3/4" (1.9 cm)	1 5/8" (4.128 cm)	3 1/4" (8.255 cm)	3 1/2" (8.89 cm)	1 1/16-12UNJ - 3A	.75 / .341
1" (2.54 cm)	1 5/8" (4.128 cm)	3 1/2" (8.89 cm)	4" (10.16 cm)	1 5/16 -12UNJ-3A	1.3 / .627
1 1/4" (3.175 cm)	2" (5.08 cm)	3 7/8" (9.84 cm)	4 3/8" (11.11 cm)	1 5/8 -12UNJ-3A	1.75 / .795
1 1/2" (3.81 cm)	2 1/8" (5.4 cm)	4 3/8" (11.11 cm)	4 5/8" (11.75 cm)	1 7/8 -UNJ-3A	2.31 / 1.05
2" (7.62 cm)	2 3/4"(6.985 cm)	4 3/4" (12.1 cm)	5 3/8" (13.65 cm)	1 1/2 -12UNJ-3A	3 / 1.36

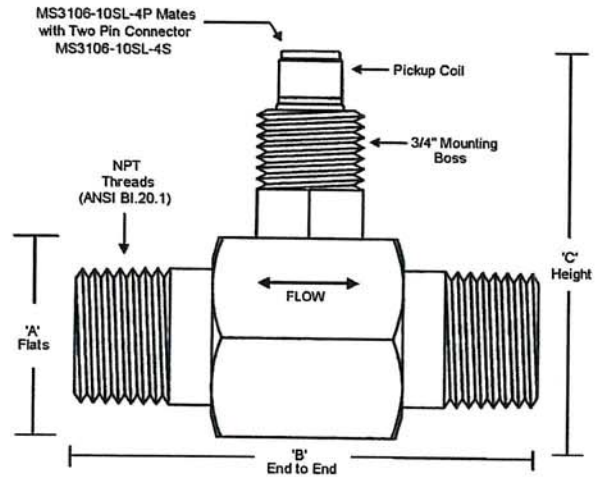

MNPT Sizes 1/4" – 3" (0.635 - 7.62 cm)

SIZE INCHES(CM)	DIMENSIONS INCHES (CM)			END CONNECTIONS	APPROX. WT. INCHES (CM)
	A	B	C		
1/4" – 1/2" (0.635 - 1.27 cm)	1 1/8" (2.8575 cm)	3" (7.62 cm)	3" (7.62 cm)	1/2" (1.27 cm)	.38 / .173
5/8" (1.59 cm)	1 1/8" (2.8575 cm)	3" (7.62 cm)	3" (7.62 cm)	1/2" (1.27 cm)	.75 / .341
3/4" (1.9 cm)	1 5/8" (4.128 cm)	3 1/4" (8.255 cm)	3 1/2" (8.89 cm)	3/4" (1.9 cm)	.75 / .341
1" (2.54 cm)	1 5/8" (4.128 cm)	3 1/2" (8.89 cm)	4" (10.16 cm)	1" (2.54 cm)	1.3 / .627
1 1/4" (3.175 cm)	2" (7.62 cm)	3 7/8" (9.84 cm)	4 3/8" (11.11 cm)	1 1/4" (3.175 cm)	1.75 / .795
1 1/2" (3.81 cm)	2 1/8" (5.4 cm)	4 3/8" (11.11 cm)	4 5/8" (11.75 cm)	1 1/2" (3.81 cm)	2.31 / 1.05
2" (7.62 cm)	2 3/4" (6.985 cm)	4 3/4" (12.1 cm)	5 3/8" (13.65 cm)	2" (7.62 cm)	3 / 1.36
2 1/2" (6.35 cm)	3 1/4" (8.255 cm)	6 1/16" (15.40 cm)	5 3/8" (13.65 cm)	2 1/2" (6.35 cm)	5.5 / 2.50
3" (7.62 cm)	3 1/2" (8.89 cm)	10" (25.4 cm)	5 5/8" (14.3 cm)	3" (7.62 cm)	10 / 4.54

The Accurate Precision Turbine Flowmeter measures volume by a contour mounted turbine in the flow system. The AC signal output is detected by a transducer and interpreted by various electronic devices used for flow rate indication and totalization. **Accurate Precision Turbine Flowmeters** are engineered and manufactured to handle problems of viscosity, corrosive media, extreme temperatures, and hazardous materials. The compact, rugged design has established a new standard for flow measurement by exceeding the expectations of our industry for higher accuracy and reliability in all operating conditions.

Accurate engineers design flow systems to meet the needs of each customer's application. These processes can be automatic, semi-automatic, or manual for batch or process control, blending, and filling systems including simple rate indication and totalization. Standard or custom electronic instrumentation is available for a wide range of applications.

At **Accurate**, we believe that no matter what the application, our commitment to quality and service to our customers means that we produce the best flowmeter on the planet.

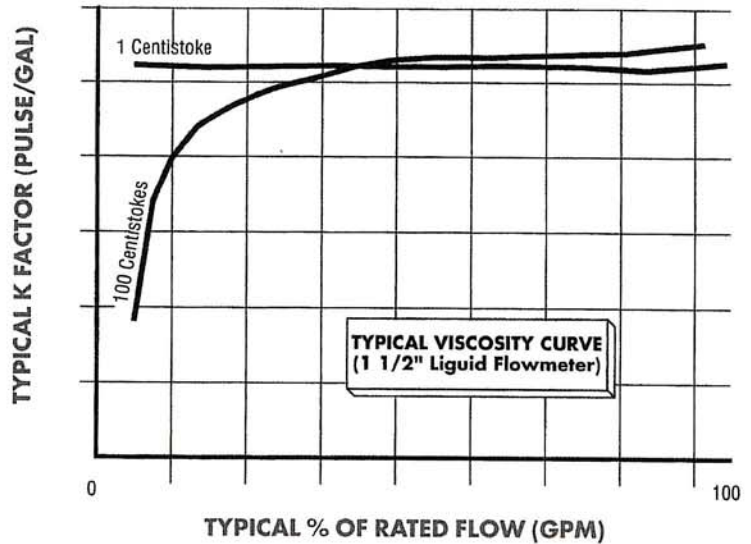
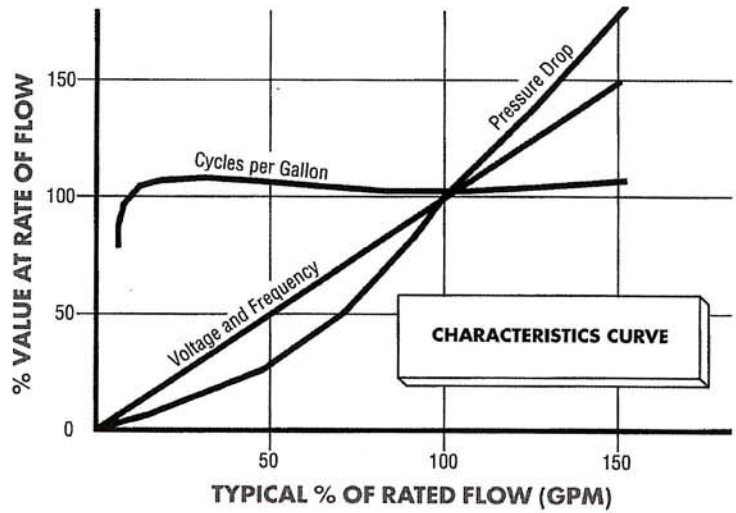

Typical Arrangement of Flowmeter and Readout Instrument

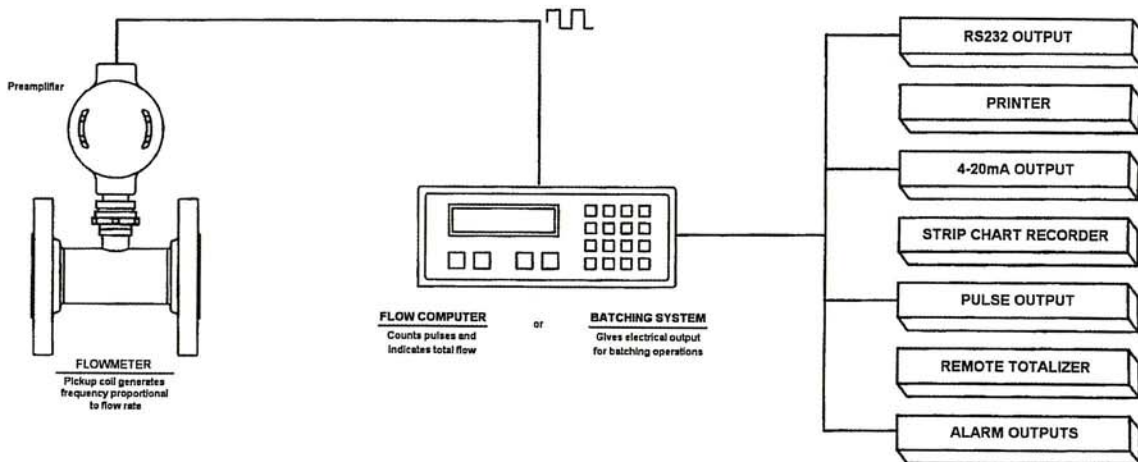

Features

- High pressure applications
- Custom and standard designs
- Manufactured in the USA
- Interfaces with manual, semiautomated or completely automated systems
- Material compatible with application
- Wide choice of bearings including carbide for compatibility

Pickup Coil:

Temperature from -450 °F (-232.2 °C) to 450 °F (267.8 °C);

Optional to 1000 °F (537.8 °C)

Materials Of Construction:

304 Stainless Steel

316 Stainless Steel

(Consult Factory for other materials.)

Standard Bearing Choices Include

Stainless Steel Ball

Ceramic Ball

Teflon Sleeve

Graphitar Sleeve

Carbide Sleeve

Fluorosint Sleeve

Standard Flow Straighteners:

Upstream and Downstream for Accuracy

Lightweight Hydraulically Balanced Rotor:

304 Nickel Liquid Rotor

17-4 PH-SS Rotor

Endfitting Choices:

Male NPT

37° Flare

Flanged

High Pressure

Tube Fitting

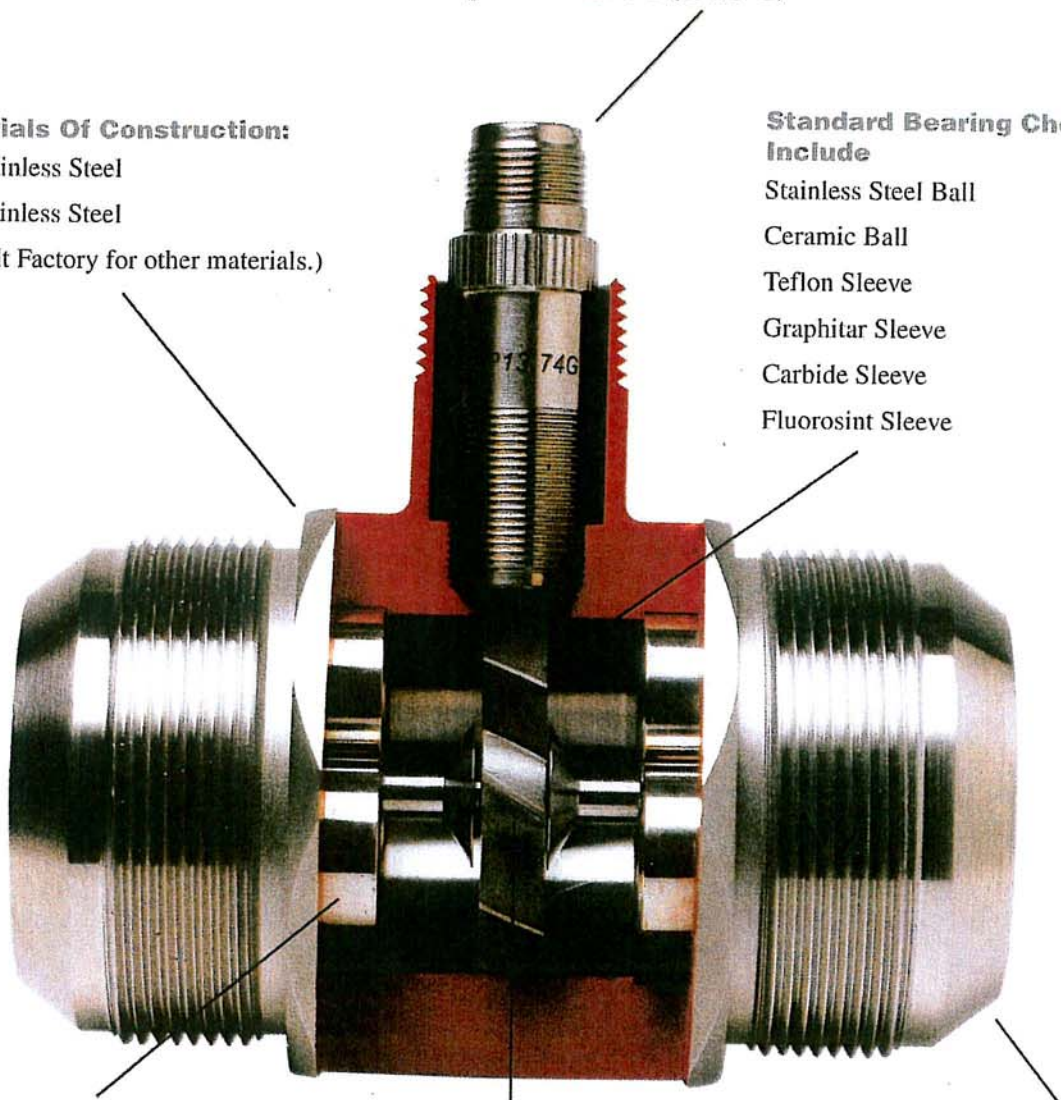

Liquids

Specifications:

- **Linearity:** +/- 0.1%
- **Premium Linearity:** +/- 0.02% (over a specific range)
- **Repeatability:** +/- 0.5%
- **Premium Repeatability:** +/- 0.2% (over a specific range)
- **Temperature:** -450°F to 450°F standard with optional 1000 °F
Temperature: -267.8°C to 232.2°C standard with optional 537.8°C
- **Materials:** Precision Turbine Flowmeters are constructed of 300 and 400 series stainless steel. A variety of other materials are available to satisfy most applications including CPVC, Teflon, and Kynar for corrosive materials.
- **Electrical Output:** A minimum of 30 mV peak to peak at the minimum of repeatable flow.
- **Pressure Drop:** 4 psi at nominal rated flow range
- **End-Fittings:** AN series of 37°, flare tube

(MS-33656), NPT, and ANSI flanges. Others available upon request.

- **Operating Pressure:** Accommodates unlimited pressure depending on the end-fittings.
- **Calibration: Accurate** Precision Turbine Flowmeters are furnished with stand fluid calibration. Special calibrations available.
- **Flow Ranges:** From .25 to 12,000 GPM
- **17 overlapping ranges standard**
Other Flow Rates available; consult factory

Note: Specifications based on ball bearings. Altering ball bearing selection may alter specifications performance. Consult factory for changes in specifications.



Sizing Chart

Size	Liquids				
	U.S. GPM / LPM				
	Minimum Repeatabile	Minimum Linear	Nominal Maximum	Extended Maximum	Approx. "K" Factor
1/4	0.25 / 1	0.5 / 2	2.5 / 10	3 / 11	15000
3/8	0.35 / 1	0.75 / 3	5 / 19	7.5 / 28	3160
1/2	0.6 / 2	1.25 / 5	9.5 / 36	12 / 45	3160
5/8	0.9 / 3	1.75 / 7	16 / 61	18 / 68	1875
3/4	1.75 / 7	2.5 / 10	29 / 110	35 / 132	1035
1	3 / 11	4 / 15	60 / 227	75 / 284	500
1 1/4	4 / 15	6 / 23	93 / 352	115 / 435	322
1 1/2	6 / 23	8 / 30	130 / 492	175 / 662	230
2	12 / 45	15 / 57	225 / 852	275 / 1041	133
2 1/2	15 / 57	25 / 95	400 / 1514	500 / 1893	75
3	30 / 114	40 / 151	650 / 2461	800 / 3028	46.1
4	50 / 189	75 / 284	1250 / 4732	1500 / 5678	20.7
5	100 / 379	140 / 530	2000 / 7571	2500 / 9464	9.0
6	125 / 473	200 / 757	2900 / 10978	3600 / 13627	5.6
8	280 / 1060	330 / 1249	5200 / 19684	6400 / 24227	2.4
10	550 / 2082	650 / 2461	8000 / 30283	9800 / 37097	5.95
12	800 / 3028	900 / 3407	12000 / 45425	15000 / 56781	5.95

* Approximate Weight for flanged Flowmeters

Gases

Accurate Precision Turbine Gas Flowmeters are designed to measure actual cubic feet or actual volume passing through the flowmeter. Before sizing a flowmeter, it is necessary to convert flow units (i.e. SCFM, LPM, etc.) to actual measured volume. To convert to actual measure volume (ACFM) from standard volume (SCFM), use the following formula:

$$\text{ACFM} = \text{SCFM} \times 14.7 / P_a \times T_a / 530$$

Whereas:

ACFM = actual cubic feet per minute measured gas flow

SCFM = standard cubic feet per minute measured gas flow

P_a = Operating Pressure in PSIA
(Note: PSIA = PSIG + 14.7)

T_a = Temperature in degrees Rankine = $F + 460$



Specifications:

- Accuracy of +/- 1% linear
- Repeatability of +/- .25%
- Temperature Range -450°F to 450°F standard with optional 1000 °F
Temperature Range -267.8°C to 232.2°C standard with optional 537.8°C

Sizing Chart

Size	Gas (ACFM / Cubic Meters)				Meter Weight *
	Flow Range		Extended Flow Range		
	Minimum Linear	Maximum Linear	Minimum Linear	Maximum Linear	
1/4	0.35 / .011	3.5 / .10	0.2 / .006	3.5 / .1	2 / 1
3/8	0.75 / .02	5 / .14	0.3 / .008	10 / .28	2 / 1
1/2	1.0 / .03	10 / .28	0.6 / .02	12 / .34	2 / 1
5/8	2.0 / .06	20 / .56	0.9 / .03	20 / .56	2 / 1
3/4	2.5 / .07	28 / .80	1.5 / .04	35 / .99	4 / 2
1	4 / .11	60 / 1.7	2 / .06	75 / 2.1	5 / 2.5
1 1/4	6 / .17	100 / 2.8	3 / .08	100 / 2.8	7 / 3
1 1/2	8 / .23	130 / 3.7	5 / .14	150 / 4.2	8 / 3.5
2	15 / .42	250 / 7.1	11 / .31	250 / 7.1	13 / 16
2 1/2	25 / .71	450 / 12.7	15 / .42	500 / 14.2	18 / 8
3	40 / 1.1	650 / 18.4	---	---	19 / 8.5
4	75 / 2.1	1200 / 34	---	---	36 / 6
5	150 / 4.2	1800 / 51	---	---	47 / 21
6	250 / 7.1	2900 / 82.1	---	---	58 / 26
8	330 / 9.3	5000 / 141.6	---	---	119 / 54
10	650 / 18.4	7500 / 212.4	---	---	226 / 103
12	900 / 25.49	12000 / 339.8	---	---	345 / 157

* Approximate Weight for flanged Flowmeters

Installation Dimensions

End Flanged

- Flowmeter sizes are based on nominal inside diameter of pipe.
- Special flanges can usually be provided to specification.
- For hazardous areas, pickup coils with explosion proof housings can be provided.
- All flowmeters 1/2" and smaller will be provided with 1/2" end connections unless otherwise specified.

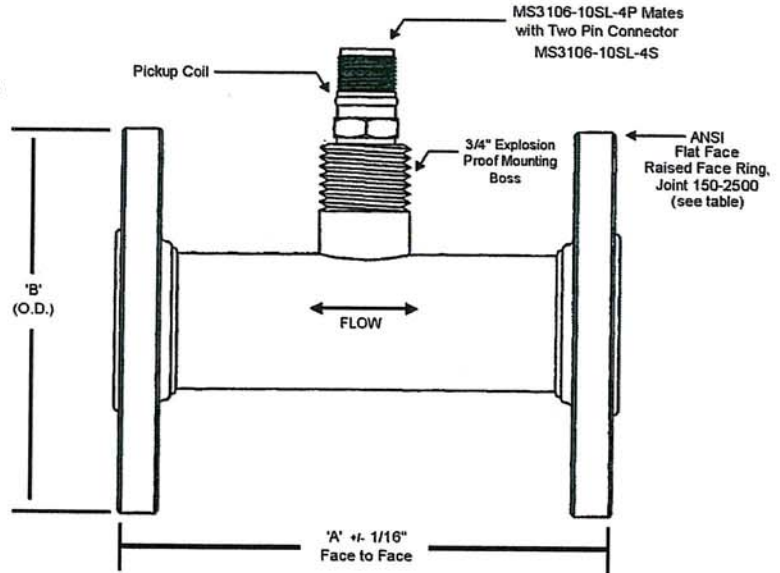

Sizes 1/2" - 12"

Stainless Steel
Unless Otherwise Specified

LINE SIZE	150# ASA (ANSI)		300# ASA (ANSI)		400# ASA (ANSI)		600# ASA (ANSI)		900# ASA (ANSI)		1500# ASA (ANSI)		2500# ASA (ANSI)	
	A	B	A	B	A	B	A	B	A	B	A	B	A	B
1/4"-1/2"	5	3 1/2	5	3 3/4	5	3 3/4	5	3 3/4	7	4 3/4	7	4 3/4	7	5 1/4
* 5/8"	5 1/2	3 1/2	5 1/2	3 3/4	5 1/2	3 3/4	5 1/2	3 3/4	7	4 3/4	7	4 3/4	7	5 1/4
3/4"	5 1/2	3 7/8	5 1/2	4 5/8	5 1/2	4 5/8	5 1/2	4 5/8	7	5 1/8	7	5 1/8	7	5 1/2
1"	5 1/2	4 1/4	5 1/2	4 7/8	5 1/2	4 7/8	5 1/2	4 7/8	8	5 7/8	8	5 7/8	8	6 1/4
1 1/4"	6	4 5/8	6	5 1/4	6	5 1/4	6	5 1/4	8	6 1/4	8	6 1/4	8	7 1/4
1 1/2"	6	5	6	6 1/8	6	6 1/8	6	6 1/8	9	7	9	7	9	8
2"	6 1/2	6	6 1/2	6 1/2	6 1/2	6 1/2	6 1/2	6 1/2	9	7	9	7	9	8
2 1/2"	7	7	7	7 1/2	7	7 1/2	7	7 1/2	10	9 5/8	10	9 5/8	10	10 1/2
3"	10	7 1/2	10	8 1/4	10	8 1/4	10	8 1/4	10	9 1/2	10	10 1/2	11	12
3 1/2"	12	8 1/2	12	9	12	9	12	9	-	-	-	-	-	-
4"	12	9	12	10	12	10	12	10 3/4	12	11 1/2	12	12 1/4	12	14
5"	14	10	14	11	14	11	14	13	14	13 3/4	14	15 1/2	16	19
6"	14	11	14	12 1/2	14	12 1/2	14	14	14	15	14	15 1/2	16	19
8"	16	13 1/2	16	15	16	15	16	16 1/2	16	18 1/2	16	19	18	21 3/4
10"	20	16	20	17 1/2	20	17 1/2	20	20	20	21 1/2	20	23	22	26 1/2
12"	24	19	24	20 1/2	24	20 1/2	24	22	24	24	24	26 1/2	24	30

* Mates to 1/2" ANSI Flange

Typical Flowmeter System Installation

